

KÜHTREIBER®

Plasma Torch PT 60

WITHOUT HIGH FREQUENCY

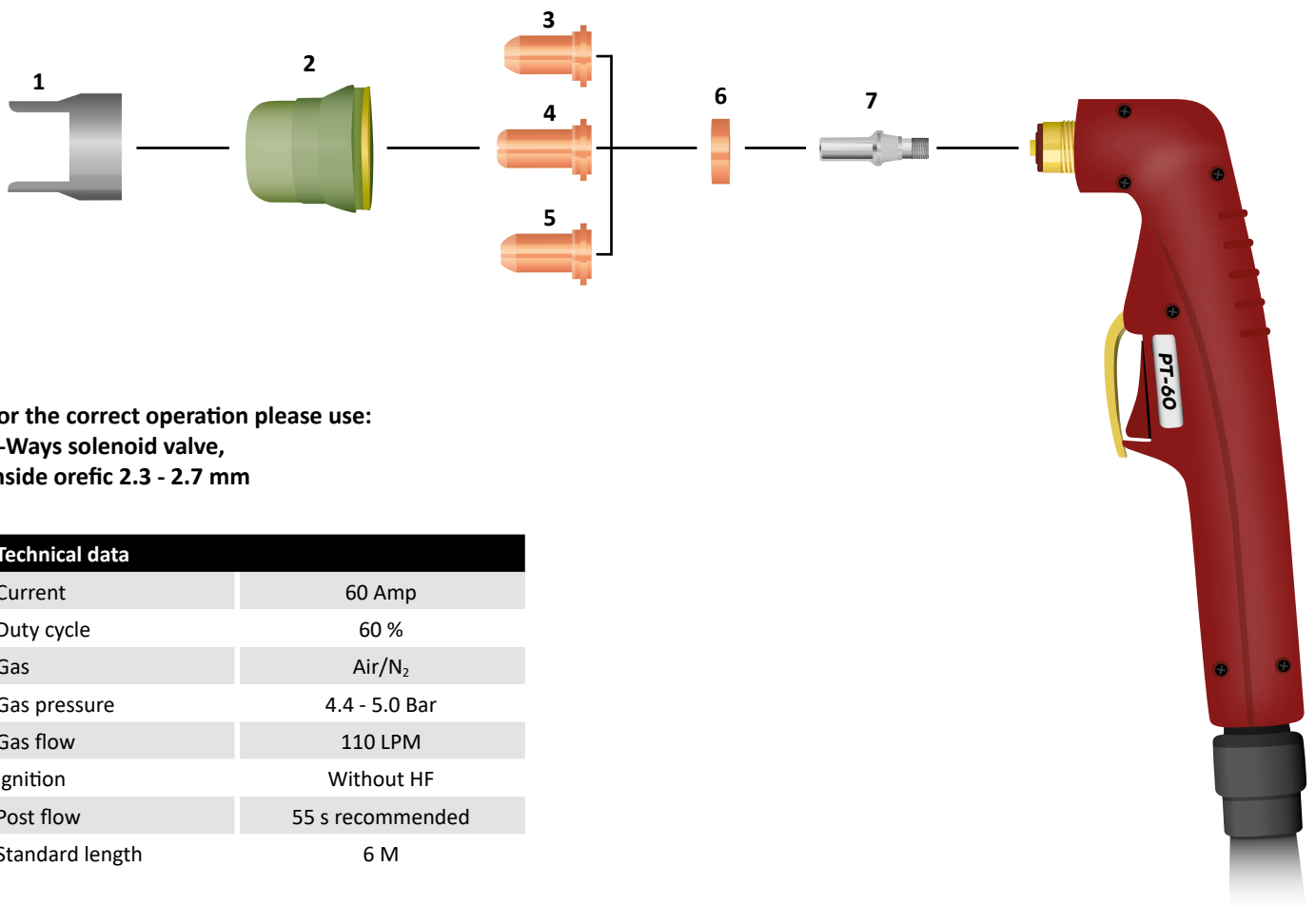

For the correct operation please use:
3-Ways solenoid valve,
inside orific 2.3 - 2.7 mm

Technical data	
Current	60 Amp
Duty cycle	60 %
Gas	Air/N ₂
Gas pressure	4.4 - 5.0 Bar
Gas flow	110 LPM
Ignition	Without HF
Post flow	55 s recommended
Standard length	6 M

Position	No.	Description
1	068710096	Double pointed spacer PT 60
2	068710095	Outside nozzle PT 60
3	068710074	Ø 0.9 mm / 30 - 40 A
4	068710075	Ø 1.0 mm / 40 - 50 A
5	068710076	Ø 1.1 mm / 50 - 60 A
6	068710097	Diffuser PT 60
7	068710073	Electrode Plasma PT 60